

TECHNICAL RIDER

THE LITTLE GIRL AND THE BIRDS

INFORMATION ABOUT THE SHOW

Synopsis

The Little Girl and the Birds is a wordless tale that features shadow projections on a big screen accompanied by music performed live by Oriane Smith. It is a visual poetry that invites the audience to take part in an immersive experience that leads them to follow the journey of a little girl who is attracted by a mysterious bird. She finds herself in a secret cave under an old tree, where she discovers a cloth bag. But the bag keeps filling itself with birds as the little girl tries to bring it back home, beyond the maze of roots she must navigate to find the exit.

At first, the birds are frail young chicks, so delicate you'd think they were made of dust, but they soon grow into a multitude of feisty, wild birds asking to be released so that they can fly away. Caught in this whirlwind of bird cries and dust, will the little girl be able to calm them down and find her way home? It is by trusting what is hidden deep within her and following her intuition that she will allow herself to be guided by the cry of a single bird who will lead her to the exit, and onto new opportunities to explore life.

Target audience: all ages from 5 years old

Show Length: 30- 40 minutes

Type of Show: No lyrics, shadow puppetry, video projection and live musician

Capacity: about 300 persons

OUTDOOR VERSION

Scenic space

- This show is played at dusk during summer and fall (June to September)
- The show is played on video screen. A space protected from rain and wind must be provided to protect the screen and projector placed behind the screen.
- Minimal space must be 20ft deep by 12 ft to 25 ft large. The public must not be able to pass between the screen and the projector.
 - * *Refer to plan for more precisions.*

Set-up: 2 hours before the show

Technicians needed: 2 technicians will be necessary

Strike: 1 hour

Number of people on tour: 1 musician and 1 TD/stage manager

TECHNICAL AND MATERIAL NEEDS

The programmer must provide a space with enough electricity and electric cables to power supply lights, sound, video, the musician's instrument, the light and sound boards and one computer.

LIGHTING

For the outdoor version, the company (TAE) provides the light board and two dimmer packs. The programmer must provide enough electricity to supply a minimum of one electrical outlet of 20 amps or two electrical outlets of 15 amps for the lighting equipment.

- 1 Source Four 26° (575W)
- 1 Fresnel (500W) with barn doors
- 2 booms of 8ft
- 1 iris

SOUND

For this show, we have one musician who plays violin and piano plus the stage manager who sends sound cues from a computer.

- Sound board with a minimum of 4 entry channels
- 1 cable ¼ jack to plug-in the violin
- 1 cable ¼ jack to plug-in the piano
- 2 speakers for the public
- 1 monitor for the musician
- Enough cables to wire the sound board, the speakers and the instruments.

VIDEO

The programmer must provide a space that can protect the projector from the weather (gazebo, tent, etc.). Ideally, the programmer provides a space that's 8 ft large where we can attach the structure of the screen. If it is not possible, the programmer must provide a minimum of 8 sandbags to stabilize the structure in case of gusts of wind.

- One free supporting screen 6 ft x 8 ft (provided by TAE)
- One projector (provided by TAE)

PROPS

- Minimum of 8 sandbags if the screen cannot be attached to a structure.
- 1 table for the stage manager
- 2 chairs

This floorplan is only there for more precisions. It is not a final version to use for the set-up. A new version will be provided to you by the Technical Director adapted to the needs of your venue.

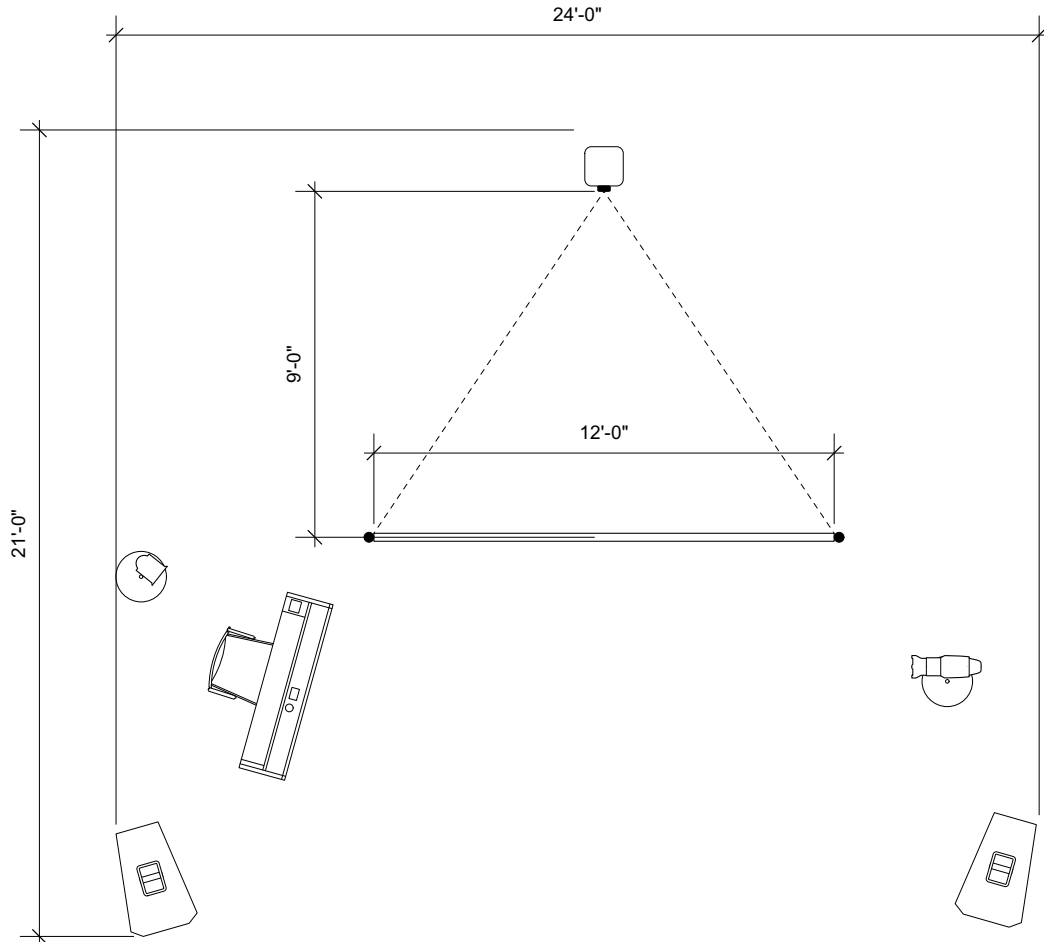

INDOOR VERSION

Scenic space

- Ideally, minimal space must be 25 ft deep by 35 ft width. Minimal height of the grid must be 11ft from the stage, but a version using the small screen that we use for the outside version is also available.
- The venue must provide enough darkness for the shadow puppets and the video projection.

Set-up: 4 hours before the show

Technicians needed: 2 technicians will be necessary

Strike: 1.5 hour

Number of people on tour: 4 performers and 1 TD/stage manager

TECHNICAL AND MATERIAL NEEDS

LIGHTING

- 1 light board
- 3 Source Four 26° 575w
- 4 Fresnel 500w with barn doors
- 1 6 ft boom
- 1 iris
- 3 adaptors TL3 male to U-ground female

SOUND

For this show, we have one musician who plays violin, piano and sings plus the stage manager who sends sound cues from a computer. One of the performers also has a microphone to produce sound effects.

- Sound board with a minimum of 6 channels.
- 1 cable ¼ jack of 25 ft to plug-in the violin (the musician moves on stage)
- 1 cable ¼ jack to plug-in the piano
- 2 wireless headset microphones (provided by TAE)
- 2 speakers for the public
- 1 monitor for the musician

VIDEO

The show can be presented on two different screen formats depending on the different venues. For Théâtre à l'Envers to be able to present the show in the best conditions, the venue must either have a grid or pipes on which the screen can be hanged. The other option is that TAE brings his own screen with a free-standing structure. Verify the details with the TD.

- 1 projector (provided by TAE)
- Screen #1: 33 ft x 12 ft (can be folded on the sides and at the bottom if needed)
- Screen #2: 12 ft x 6 ft

SOFT GOODS

The soft goods will be different depending on which screen we bring:

- 2 legs (minimal height of 12 ft and width depending on the venue)
- 1 border (it has to cover 1ft of the top of the screen and all the way up to the grid).

PROPS

- 2 chairs (one for the musician and one for the stage manager)
- 2 large tables for the shadow performers
- 5 U-ground cables of 25 ft.
- 2 backstage lights and 1 for the stage manager

This floorplan is only there for more precisions. It is not a final version to use for the set-up. A new version will be provided to you by the Technical Director adapted to the needs of your venue.

